

## Micron MR601a Quick Start Guide

This guide is designed to get you started with MR601a as quickly as possible. More information can be found in the user manual - <http://micronrc.uk/mr601-info>.

**MR601a** receiver is 2.4GHz DSM2/DSMX receiver, with 1.2A max brushed speed controller, for use in larger scale model rail locomotives and road vehicles. It is compatible with any Spektrum DSM2 or DSMX transmitter including all of the Micron [model rail transmitters](#). The voltage range is 5V to 20V.

If purchased with a transmitter, MR601a will be bound to the transmitter and is ready for use; otherwise, it requires binding to your transmitter. Once bound, the transmitter should be switched on before the MR601a. If the transmitter is not switched on, MR601a will automatically enter bind mode 10 seconds after switch on.

### Usage

- Do not bend the receiver circuit board
- Connect the positive and negative input pads to a suitable battery or power supply, via a on/off switch in the positive lead. A resettable fuse **must** be placed in the battery positive lead to protect the battery in the event of a wiring or component fault.
- Connect the 'M' pads to your vehicle motor, removing any connections to track pickups. If your loco has suppression capacitors or chokes fitted, leave them in place. It is not usually necessary to fit suppression components if your loco do not already have them. Contact Micron if you do experience symptoms of motor noise interference.
- Connect any auxiliary circuits to the F and P pads; the P pads are 3.3V pads when on and may be used for powering auxiliary circuits with a maximum of 20mA per pad. F pads are switches, open circuit when off and connected to negative when on.
- Protect the receiver board before applying power for testing. It must not be allowed to touch anything metal. If MR601a was purchased with the heatshink cover supplied loose, slide this over the circuit board.
- After switching on:
  - the LED will slow flash while MR601a is searching for its bound transmitter; if not already bound, approx 10 seconds later the receiver will go into bind mode and the LED will show a rapid flash; switch your transmitter on in bind mode and the LED flashing will slow while the transmitter and receiver are synchronising and then light continuously. If the LED continues rapid flashing or the slower flashing does not stop, try again with the transmitter slightly further away from MR601a - for most transmitters, 50cm separation works well.
- When bound:
  - the LED will be on to show receipt of good data from the transmitter,
  - the LED may flicker due to electrical (e.g motor) noise, signal fades caused by reflections, interference from WiFi or Bluetooth signals, or overloading from the transmitter (this will happen if the transmitter is too close)
  - the LED will show a slow repeated flash if the transmitter signal is lost - e.g. if the vehicle has gone out of range for more than 1 second or you have switched the transmitter off
  - the LED will show a repeated double flash when MR601a is deselected (transmitter Selecta switch is moved)
  - the CPU LED will show a repeated 5 flash if the low voltage cutoff has triggered
- After testing, apply the heatshrink cover if not already fitted.
- Fix the receiver in place and, an extended aerial is fitted, route this so that the last 30mm can 'see' the transmitter - e.g. by routing through a hole in the vehicle body. The aerial should not be cut short or made longer as this will affect operation. It is important to perform a range check after installation to ensure you have full control of your loco/vehicle at all positions around the layout. Double sided foam-cored sticky tape is ideal for mounting the receiver.

## Connections

MR601a has solder pads for:

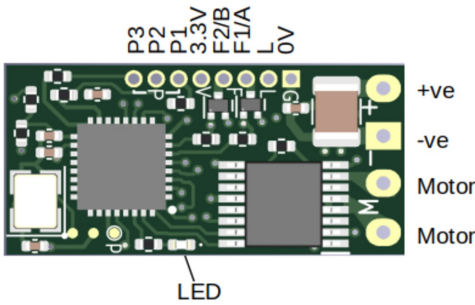

- power input (positive & negative battery)
- motor output
- 3.3V from the on-board regulator (max of 200mA - **DO NOT** use to power servos)
- an additional battery negative connection (0V) - useful for wiring LEDs to P pads
- L: used to monitor battery voltage when a booster module is used, e.g. to raise a single LiPo cell to 12V.
- P1..P3: these are logic level outputs, 0V when off and 3.3V when on; they can be configured for on/off switching or to output a servo signal
- F1 & F2: these are FET switches capable of up to 1A; they are open circuit when off and connected to battery negative when on; a load should be wired between the F pad and battery positive, or the 3.3V pad for low current loads; they are labelled A & B on the receiver board and numbered 4 & 5 for programming

The simplest use of MR601a requires connection to a battery (via an on/off switch and resettable fuse) and to your loco/vehicle motor.

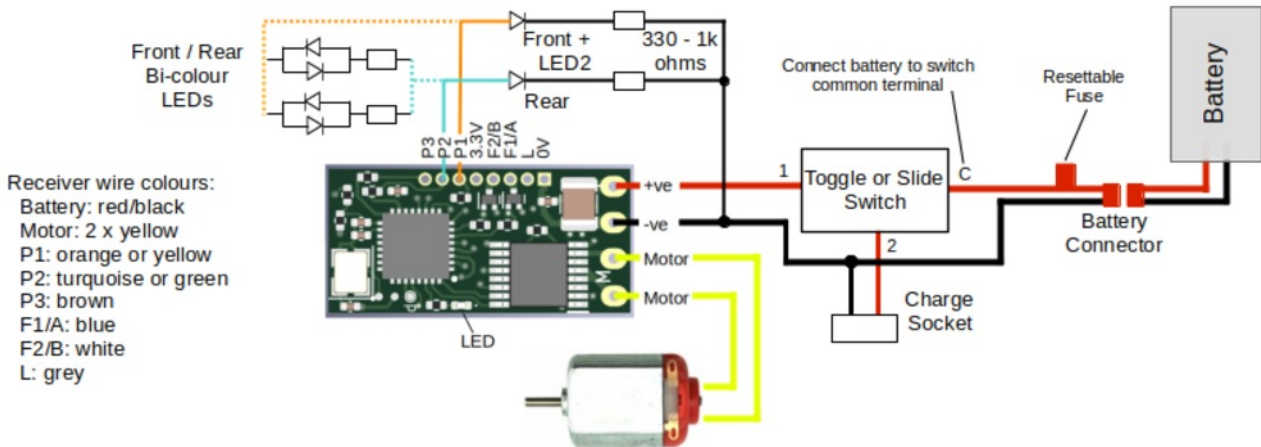

The default speed controller PWM frequency is 16kHz which works well for small and coreless motors. Larger motors may exhibit a reduced throttle response at this high frequency and will benefit from lowering to 1kHz or 500Hz - experience with Re280 type motors shows that 500Hz or 250Hz works best. The PWM frequency may be set using power-on programming changes (from v1.7, ident 'I' - see [icronrc.co.uk/mr601-1.7-info](http://icronrc.co.uk/mr601-1.7-info)) or by programming MR601a, which requires a transmitter capable of programming receivers (e.g. Tx20, Tx22, Tx24 - not Tx10 or Tx21).

LEDs on P pads should be connected between the pad and battery negative (0V) with a series resistor appropriate to the required brightness.

Other connection diagrams (e.g. high current lights, sound card triggers) are available on the Micron MR601a web page.

**Take care** when soldering wires to the battery, motor, P and F pads as these are easily damaged by prolonged application of high temperature. A temperature controlled iron used with thin flux cored solder is best. Also, if using stranded wire, ensure that none of the strands 'escape' to short across adjacent pads.

## Binding

To bind:

1. with transmitter off, switch MR601a on
2. wait for the LED to flash fast
3. switch your transmitter on in bind mode
4. the LED flashing will slow for 2-5 seconds and then light continuously
5. MR601a is now bound to your transmitter